CONVEX
Service Plan for
EXABYTE EXB-120
Cartridge Handling System



Second Edition
June 1994

CONVEX Press
Richardson, Texas
United States of America

CONVEX
Service Plan for EXABYTE EXB-120 Cartridge
Handling System

Copyright © 1994 CONVEX Computer Corporation
All rights reserved.

This document is copyrighted. This document may not, in whole or part, be copied, duplicated, reproduced, translated, electronically stored, or reduced to machine readable form without prior written consent from CONVEX Computer Corporation.

Although the material contained herein has been carefully reviewed, CONVEX Computer Corporation does not warrant it to be free of errors or omissions. CONVEX reserves the right to make corrections, updates, revisions or changes to the information contained herein. CONVEX does not warrant the material described herein to be free of patent infringement.

CONVEX and the CONVEX logo ("C") are registered trademarks of CONVEX Computer Corporation.

UNIX is a registered trademark of UNIX System Laboratories, Inc., a wholly owned subsidiary of Novell, Inc.

FileServ is a registered trademark of E-Systems, Inc.

Unitree is a registered trademark of OpenVision Technologies.



This book is recyclable.

Printed in the United States of America

Revision information for

CONVEX

Service Plan for EXABYTE EXB-120 Cartridge Handling System

Edition	Document No.	Description
First	081-025130-000	Initial release May, 1994
Second	081-025130-001	Released June, 1994. Added FRU and corrected the preventive maintenance schedule.

Contents

Product information	1
Technical and performance information	1
Equipment specifications	2
Facility and clearance requirements	2
Required cables	4
MTBF and MTTR	4
System software requirements	6
Software distribution options	7
Service philosophy	8
Spare parts	8
Recommended tools	10
Maintenance	10
Level of repair	10
Diagnostic approach	11
Preventive maintenance schedule	12
Removing EXB-8500CD cover	12
Installation	12
Support	13
Obtaining spares and tools	13
Training	14

Service Plan for EXABYTE EXB-120 Cartridge Handling System

CONVEX now offers the EXABYTE EXB-120 cartridge handling system. The EXB-120 provides data archival and backup capability using high-performance robotics and four 8-mm Cartridge Tape Subsystems (CTS).

The current CONVEX product strategy is to limit the use of the EXABYTE EXB-120 to Hewlett-Packard workstations using Unitree data management software.

This document provides the service manager advanced information about the EXB-120 for planning purposes.

Product information

The EXABYTE EXB-120 is a fully automatic, random-access cartridge handling system. The EXB-120 offers a maximum of 580 GBytes using EXB-8500CD CTSs or to approximately 1,160 GBytes using EXB-8500CD CTSs with data compression.

The EXB-120 provides back up for large computer systems, automated tape library management, graphic image storage and retrieval, and access to online sequential data sets.

Technical and performance information

The EXB-120 is a highly integrated system with four major components: the robotics or Cartridge Handling System (CHM), the CTSs, the storage bins, and the system controller.

The CHM provides cartridge movement within the EXB-120. It can move a data cartridge from one storage bin to another, from a storage bin to a CTS, and from the entry and export port to a storage bin. The CHM receives command and control information from the SCSI-based system controllers.

The EXB-8500CD drives use helical-scan technology to provide high data storage capacities on 8 mm data cartridges. A single cartridge can store up to 10 GBytes.

The EXB-120 holds up to 116 tape cartridges in eleven removable ten-cartridge holders (ten-pack).

System control is provided by SCSI-based controller cards using the standard SCSI command set. In addition to remote control capability, the EXB-120 has an operator control panel which allows manual control and tape import and export.

Equipment specifications

The equipment specifications are listed in Table 1:

Table 1 EXABYTE EXB-120 specifications

Cartridge capacity	116
Tape drive capacity	4
Host computer interface	SCSI, Differential
Average cartridge access time	20 seconds
Mean swaps per hour	160
Operating temperature	41°F to 95°F (5°C to 35°C)
Power consumption (maximum)	310 VA (with 4 drives)
Weight, empty	271 lb (122.9 kg)
Weight, fully loaded (4 drives, 116 cassettes)	306 lb. (138.8 kg)
Height	51.5in (130.0 cm)
Width	22 in (55.9 cm)
Depth	24 in (61 cm)

Facility and clearance requirements

The EXABYTE EXB-120 requires a room large enough for storage operation and maintenance. These requirements are detailed in this section.

Clearances

Figure 1 shows dimensions of the EXB-120, allowing site administrators to plan for doorway clearance and service area. The ceiling of the operations room must be at least eight feet.

Figure 1 EXABYTE EXB-120 outline dimensions

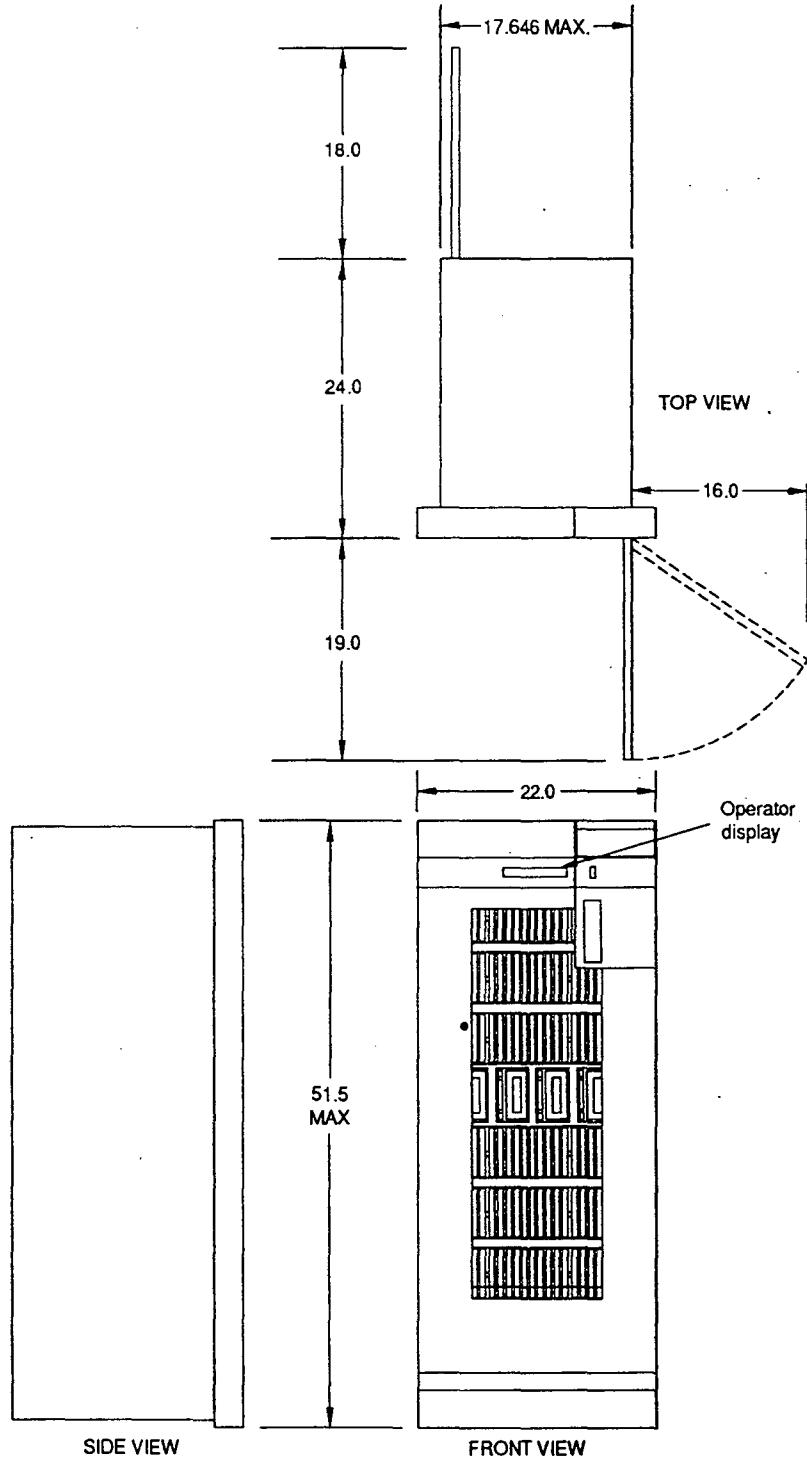

EXB1
5/10/94

Power requirements

The EXB-120 has an autoranging power supply that accepts 90 to 132 vac or 175 to 264 vac, single phase, 47 to 63 Hz. The nominal service capacity must be either 5 amperes for 117 vac or 2.5 amperes for 220 vac. The EXB-120 is shipped with a 2-meter (6.58-foot) three conductor power cord with a molded NEMA 5-15P male connector on one end and a molded IEC type CEE-22 female connector on the other. For the type power cord required in your region follow the local electrical codes and order the connector locally. Clearly mark the service for electrical hazards, and provide a shunt trip for emergency power off.

Environmental requirements

Table 2 shows the environmental requirements of the EXB-120.

Table 2 EXABYTE EXB-120 environmental requirements

Operational temperature	41°F to 95°F (5°C to 35°C)
Non-operational temperature	-41°F to 140°F (-41°C to 60°C)
Operational temperature change	±18°F (±10°C)
Non-operational temperature change	±36°F (±20°C)
Recommended operating humidity	40% to 60% non-condensing
Operational humidity	20% to 80% non-condensing
Non-operational humidity	10% to 90% non-condensing
Altitude	10,000 feet (3,000 meters) maximum

Do not install the EXB-120 next to equipment that radiates excessive radio frequency interference.

Required cables

Each EXB-120 requires the following:

- Internal SCSI (included with every shipment).
- External SCSI for connection between Centronics port and HP workstation.
This SCSI cable can vary in length to approximately 70 feet.
- Differential SCSI cable terminator (shipped with every EXB-120).

MTBF and MTTR

All components of the EXB-120 have been designed to be field-replaceable. The mean-time-between-failures is estimated to be in a range from 2,800 hours for 50% duty cycle to 2,050

hours for a 70% duty cycle. The time to replace any FRU is approximately 30 minutes. If, however, the FRU replacement requires mechanical realignment of the robotics, the time to repair could approach four hours.

Caution

Placement of the bar-code labels on the tape cartridges must be done per the EXABYTE EXB-120 Cartridge Handling Specification or picker problems may occur.

Caution

Use only EXATAPE to prevent voiding the warranty. Never use video grade tapes such as the ST-120 in the EXB-120 and EXB-8500CD. For tape drive head cleaning, use only the EXB-DR cleaning cartridge. Other tapes must be qualified by CONVEX.

System software requirements

The EXB-120 may be used on HP 735/755 systems. The only hardware requirement is that the system have a fast, narrow, differential small-computer system interface (SCSI) port that uses five logical units. To use the EXB-120 on the Hewlett-Packard system, the software listed in Table 3 must be installed.

The EXB-120 requires the Hewlett-Packard HP-UX v9.01 or higher operating system (CONVEX part number to be determined) and Unitree 1.7.x data management software. Unitree software is licensed based on the amount of data stored in the system. Each installation will need the Unitree Software kit, the base license, and the LTU license.

Order Unitree software by normal sales order procedures. When ready to install the software, call the TAC for a validation key. The part number for the basic software kit and the site license are listed in Table 3.

Table 3 Unitree licensing

Convex part number	System storage size
750-001522-xxx	Unitree Software Kit
750-000490-000	Unitree base license
750-000749-005	560 GBytes
750-000749-006	900 GBytes
750-000749-007	1.4 TBytes
750-000749-008	2.5 TBytes
750-000749-009	5 TBytes
750-000749-010	10 TBytes
750-000749-011	50 TBytes
750-000749-012	100 TBytes
750-000749-013	500 TBytes
750-000749-014	1,000 TBytes
750-000749-015	5,000 TBytes
750-000749-016	10,000 TBytes
750-000749-200	Source LTU

Future plans may include the use of the Hewlett-Packard 800 series computers as a customer-independent sourcing selection. At this time, CONVEX does not plan to sell nor provide service

for the HP800 series products. The customer must contract service directly from Hewlett-Packard.

Software distribution options

All software updates and revisions will be distributed on either digital audio tape (DAT) or compact disc read-only memory (CDROM). The appropriate media selection will depend upon the customer configuration and should be communicated to the CONVEX software distribution group via the original sales order.

Service philosophy

CONVEX is the primary service provider for the EXB-120. This service consists of three levels. The first level is the response to the customer problem call. When the problem call requires corrective (or preventive) maintenance, a service engineer (SSE) is dispatched to the customer site to troubleshoot the problem. Second-level service is fixing the problem with the appropriate spare parts. Third-level service is technical backup from CONVEX headquarters. Personnel with the appropriate expertise are on standby to resolve problems with either the SSE or the customer in some cases. Service personnel require proper training, tools and spare parts before down-time can be kept within specification.

Spare parts

Service engineers perform field preventive and corrective maintenance activities on certain components of the system. Table 4 shows these field replaceable units (FRUs).

The distribution of spares will be managed over time. The stocked spare parts list is subject to change as CONVEX gains experience.

Table 4 EXABYTE EXB-120 FRUs

CONVEX P/N	Vendor P/N	Description	Stocked by CONVEX
621-000108-001	727386	EXB DR 8mm cleaning cartridge	X
900-000801-001	727512	Cable, GRBRFLEX-XZFLEX card (Z-axis flex)	X
900-000801-002	F727246	Z-axis assembly	X
900-000801-003	F727259	Y-axis motor	X
900-000801-004	F727268	X-axis motor	X
900-000801-005	727271	Light fixture	
900-000801-006	727126	Cable, driver interface	
900-000801-007	F781501	X FLEX card	X
900-000801-008	F781801	Cable, RY RX flex	X
900-000801-009	F781900	Limit A card	
900-000801-010	F783200	Limit B card	
900-000801-011	F000154	Power supply, +5v, +12v	X
900-000801-012	F727802	Power supply, +24v	X
900-000801-013	727123	Cable, display	
900-000801-014	727514	Cable, XFLEX card-XZFLEX card (X-axis flex)	X
900-000801-015	727513	Cable, BRFLEX card-barcode (plunge flex)	X

Table 4 EXABYTE EXB-120 FRUs (continued)

CONVEX P/N	Vendor P/N	Description	Stocked by CONVEX
900-000801-016	F81303	Display card	X
900-000801-017	F781201	Driver card	X
900-000801-018	F733000	Media changer card	X
900-000801-019	000507	Light Bulb F8T5/CX, 16W	X
900-000801-020	000266	Light Bulb F6T5/CX, 16W	X
900-000801-021	000302	Z-axis motor belt	X
900-000801-023	302437-001	Cable, SCSI data	
900-000801-024	000299	Y-axis driver belt	
900-000801-025	000303	Y-axis motor belt	
900-000801-026	000301	X-axis driver belt	
900-000801-027	000298	X-axis motor belt	
900-000801-028	727244	Ten-pack cartridge holder	
900-000801-029	783300	Power interrupt PWB assy	X
207-000034-200	EXB-8500CD	Tape Drive/Differential	X

Recommended tools

In addition to the tools in the standard toolkit, the SSE must be sure to include the following TORX driver bits: T-25, T-20, T-10, T-8, and T-6. An alignment tool, CONVEX part number 900-000801-022 (Exabyte number 302948-000), is also required.

Maintenance

Preventive maintenance (PM) consists of periodically replacing certain components; corrective maintenance (CM) consists of troubleshooting, replacement or repair, and adjusting or calibrating failed FRUs. Preventive maintenance consist of two categories: operator and service PM. Operator's PM is regular inspection and cleaning of the EXB-120. Service PM is performed by service personnel and is the regular replacement of key items that are subject to failure over time.

Level of repair

The level of repair is determined by the local Field Support management. With training, all adjustment and cleaning can be performed by CONVEX SSEs. Failed FRUs are diagnosed and replaced by the SSE and returned to CONVEX via the logistic procedures appropriate for the region. The spares listed in Table 4 are required to adequately maintain the EXB-120. These spares will normally be stocked at the depot level.

For logistic procedures contact:

	Primary contact	Region	E-mail login	Phone number
Headquarters Spares Depot	Barbara Lester	US, S. America, Asia, and Pacific	lester	(214) 497-4216
European Distribution Center	Jorge Torres	Europe	torres	31-20-6540251 (Holland)

Diagnostic approach

In addition to error messages and error codes displayed on the operator's panel, the EXB-120 has firmware that allows the SSE to perform the following diagnostic procedures:

1. Viewing machine status
2. Upgrade to new firmware
3. Viewing a dump of EXB-120 history
4. Manually controlling the cartridge handling mechanism

Power-on self tests

The EXB-120 has a power-on self-test capability that checks the CHM.

Cartridge Tape Subsystem power-on self-test

Each CTS has a power-on self-test that is independent of the CHM. This test requires up to 65 seconds, depending on the configuration.

Preventive maintenance schedule

The EXB-120 requires periodic cleaning. CONVEX recommends the following preventive maintenance activities be performed once a month or every 30 tape-motion hours. Tape motion hours is the time the tape is in contact with the drive heads.

- Clean the window in the front door.
- Wipe off dust on data cartridge holders and data cartridges.
- Clean the heads of each CTS with the Exabyte tape drive cleaning cartridge.

Each EXB-120 must contain two cleaning cartridges. Clean each drive periodically every

- 30 GBytes of data transferred
- 30 tape motion-hours
- 15 tape cartridges inserted

Caution

Use of any cleaning cartridge other than the Exabyte cartridge will void product warranty.

- Under normal use, change the cleaning cartridges every 12 months.

Removing EXB-8500CD cover

The serial number and configuration end item (CEI number), which define the configuration of the drive, are mounted on the cover and the back of the EXB-8500CD tape drive. There is no reason to remove the covers, but if they are ever removed, please insure that each one is put back on the drive from which it was removed to not void the warranty.

Installation

CONVEX field engineering organization is responsible for installing the EXB-120. It is also responsible for installing any additional units and exchanging replacement parts. These activities should be accurately recorded by field service personnel in the appropriate reporting system.

Support

CONVEX is the primary service provider for the EXB-120. In the US, the CONVEX Technical Assistance Center (TAC) is the front line of support for SSEs and customers. In other CONVEX regions around the world, the SSE and customer should contact their local CONVEX support office. A second line of support is provided by expert personnel. These secondary points-of-contact for the EXABYTE EXB-120 are:

Point-of-contact	E-mail login	Phone number
Chris Magargee	magargee	(214) 497-4402
Kelvyn Gipp	kgipp	(214) 497-4601

Obtaining spares and tools

When an SSE requires a spare part, he/she will follow established procedures in the appropriate region to obtain that part. Questions concerning the logistics, pricing, and ordering of spare parts and tools should be directed to:

	Primary contact	Region	E-mail login	Phone number
Headquarters Spares Depot	Barbara Lester	US, S. America, Asia, and Pacific	lester	(214) 497-4216
European Distribution Center	Jorge Torres	Europe	torres	31-20-6540251 (Holland)

Training

The SSE maintaining the EXB-120 automated storage library may require a special training course provided by CONVEX. This course covers other peripheral devices than the EXB-120. The class is in the development stage at this time.

To obtain latest information for this course, contact:

Point-of-contact	E-mail login	Phone number
Chris Magargee	magargee	(214) 497-4402
Debbie Ericksen	ericksen	(214) 497-4239